



Megabit Modem® MM300SBP-G2

Quick Installation Guide

OVERVIEW

The LTI DataComm Megabit Modem MM300SBP-G2 is a versatile, ruggedized high-speed single wire pair modem used to extend an Ethernet LAN data connection in a point-to-point application (also called back-to-back) implementation to another modem. The modem uses Single-Pair High-Speed Digital Subscriber Line (SHDSL) technology with automatic rate-adaptation to achieve symmetric data rates from 64 to 2304 kbps based on the connection distance and line condition.

The modem connects through its 10/100 Base-T port to a PC or Local Area Network (LAN). The DSL port (via bare wire binding posts) provides access to the following type of connection: connection to another MM300SBP-G2 which provides access to a remote PC or small LAN via its bare wire binding posts.

Figure 1 shows the MM300SBP-G2 connected to a PC using the black straight-through cable. **Figure 2** shows the MM300SBP-G2 connected to an Ethernet Switch using the Yellow cross-over cable.



Both Black and Yellow cables can be used for the Ethernet switch connection (MDI, MDI-X port or Auto). The Ethernet switch can have either MDI or MDI-X ports. The Yellow cable is an example of one kind of Ethernet switch connection.

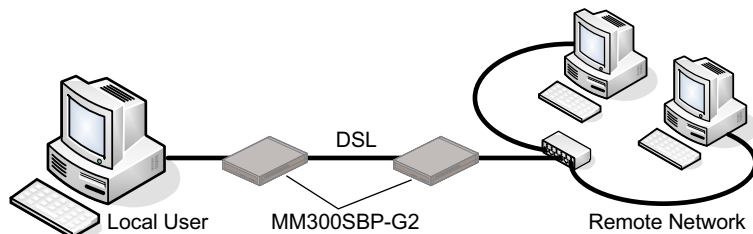

Figure 1. MM300SBP-G2 Connected Directly to PC

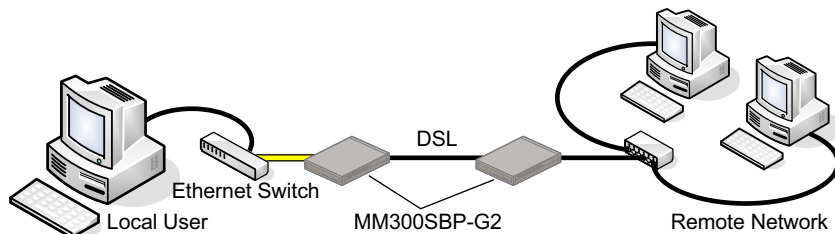

Figure 2. MM300SBP-G2 Connected to an Ethernet Switch

In this point-to-point application, one MM300SBP-G2 is automatically set to remote CPE mode while the other modem is set for Central Office (CO) mode. This negotiation takes place at modem start-up and is completely automatic. By bridging traffic between these two modems, you essentially create one extended LAN that allows the use of a single IP subnet.



Avoid using IP Address 172.17.0.1 in your network since it is used for MM300SBP-G2 internal management. If this IP Address is needed, contact Technical Support on page 8 on how this can be changed.

FEATURES

The MM300SBP-G2 provides Media Access Control (MAC) layer bridging of frames received on its LAN and WAN interfaces. It provides transparent address learning for the LAN interface. Address entries are aged out after 300 seconds. It provides transparent forwarding of VLAN and non-VLAN Ethernet frames up to 1536 Bytes.

The DSL connection requires a dedicated single-pair wire to connect the local and remote units. The modem compensates for DSL (Tip and Ring) reversals; therefore, rewiring the junction box should not be necessary.

The MM300SBP-G2 is easy to install: connect the cables and it is ready to use. The modem may be installed on a desktop or mounted on a wall.



The MM300SBP-G2 allows packet sizes up to 1536 Bytes to accommodate Virtual Local Area Network (VLAN).

TECHNICAL SPECIFICATIONS

Power Adapter	Input: 100~240 VAC, 50/60 Hz, 0.3 A Output: 6 VDC, 1.8 A
Ethernet	Link, Transmit, Receive, Collision
DSL	Sync, Transmit, Receive, Margin
Ethernet Connector (LAN Interface)	RJ-45 connector for 10/100 Base-T interface, wired as MDI-X (Ethernet Switch Configuration)
Ethernet Cables	Black straight-through full conductor 24 AWG 4-Pair UTP ETL verified to ANSI/TIA-568-B.2 Cat 5e to connect to PC Yellow cross-over data cable 24 AWG 4-Pair UTP ETL verified to ANSI/TIA-568-B.2 Cat 5e to connect to Ethernet switch
DSL Connectors	DSL Pair 1 - Binding Post P1 Tip/Ring for DSL Interface
Default DSL Margin	6 dB
Margin LED Threshold	6 dB
Number of LEDs	9
Maximum Transmission Rate to Sync	Downstream: 2304 kbps Upstream: 2304 kbps
Minimum Transmission Rate to Sync	Downstream: 64 kbps Upstream: 64 kbps NOTE: At 26 AWG, 64 kbps maximum distance is 24 kft. At 24 AWG, 64 kbps maximum distance is 33 kft.
Reset Button	Reset button performs both the reset of the CPU and "Reset to Factory Defaults".
Physical:	
Depth	5.5 in. (14.0 cm)
Width	6.75 in. (17.15 cm)
Height	1.25 in. (3.175 cm)
Weight	1.38 lb. (0.63 kg)
Environmental:	
Operating Temperature	+32 to 122°F (0 to 50°C)
Relative Humidity	up to 95% non-condensing
Operating Altitude	-200 to 13,000 ft. (-61 to 3962 meters)
Storage Temperature	-40 to 158°F (-40 to 70°C)
Storage Altitude	-1,000 to 30,000 ft. (-305 to 9144 meters)

Emissions and Immunity	CISPR 22 Class B
	FCC Part 15, Subpart B, Class B
	ICES-003
	2004/108/EC
	AS/NZS CISPR 22 Class B
Operations and Safety Compliances	UL/cUL 60950-1
	IEC 60950-1
	CE (EN 60950-1)

SAFETY INSTRUCTIONS

- Never install telephone (modem) wiring during a lightning storm.
- Never install a telephone jack in wet locations unless the jack is specifically designed for wet locations.

Use caution when installing or modifying telephone wires.

- Never touch uninsulated telephone wires or terminals unless the telephone wire has been disconnected at the network interface.

Do not use a telephone (modem) in the vicinity of a gas leak.

- To reduce the risk of fire, use only 26 AWG or larger telecommunication line cord.

VERIFY SHIPPING PACKAGE CONTENTS

Inspect the contents of the shipping package for the following:

- Modem unit
- 6-Vdc power supply with cord
- Ethernet cable (Black straight-through cable, Cat 5e)
- Ethernet cable (Yellow cross-over cable, Cat 5e)
- Green/Yellow ground wire
- Two Phillips head screws for wall mounting
- Four adhesive backed rubber feet
- Wall Mount template
- Megabit Modem MM300SBP-G2 Quick Installation Guide
- Megabit Modem MM300SBP-G2 Declaration of Conformity

PROTECTING MULTIPLE MM300SBP-G2 UNITS FROM OVERHEATING

If you plan to operate multiple MM300SBP-G2 units in a combined area, take the following precautions in order to avoid overheating the units:

- Do not stack MM300SBP-G2 units on top of each other.
- Do not place any object on top of the MM300SBP-G2 units.
- Do not obstruct the cooling vents.

1. Attach Feet

Attach one of the adhesive-backed rubber feet to the recess in each of the four corners on the bottom of the modem (Figure 3).

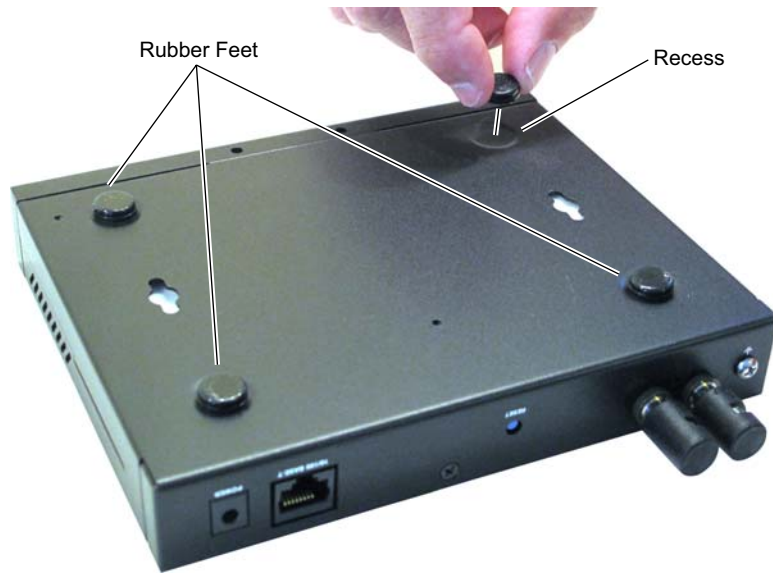

Figure 3. Attach Feet

2. Wall Mounting (Optional)

Mounting holes on the bottom of the modem provide the option to mount the modem on a wall. Two Phillips head screws are provided per MM300SBP-G2.

Step	Action
1	Use Figure 4 as a guide for wall mounting. You can also use the enclosed Wall Mount template.
2	Leave enough space to read the front panel LEDs.
3	If you have more than one modem, refer to Protecting Multiple MM300SBP-G2 Units from Overheating on page 2 .

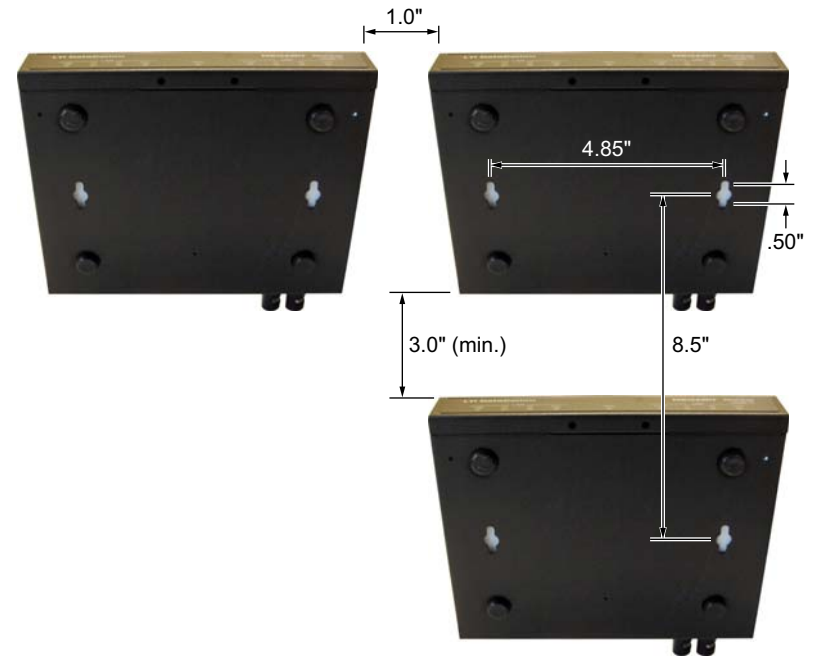

Figure 4. Wall Mount

3. Connect the Cables

Step	Action
1	Connect the cables to the ports as indicated in Figure 5 and Figure 6 . NOTE: For instruction on the Reset Button, go to Reset to Factory Defaults using the Reset Button on Page 6 .
2	Connect the cables to the modem rear panel and to the facility or other equipment as shown in Figure 6 : <ul style="list-style-type: none"> • Connect the Earth Ground. • To connect the modem to a PC, use the Black straight-through cable. • To connect the modem to an Ethernet switch, use the Yellow cross-over cable. • Connect binding post connectors for the DSL interface. • Connect the Power.

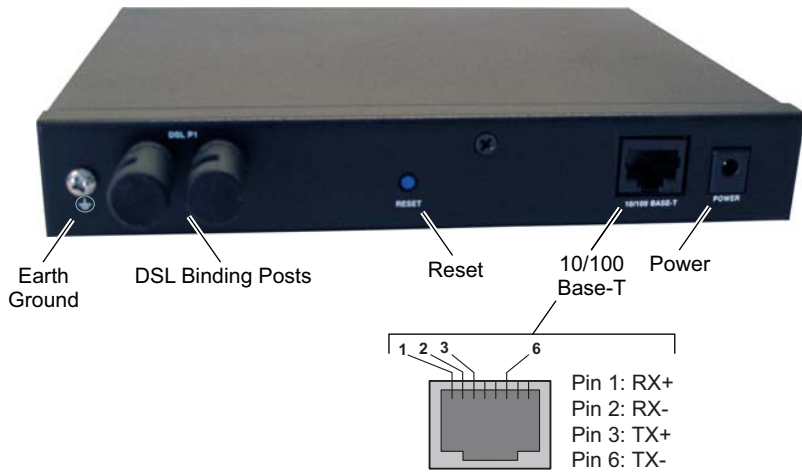

Figure 5. Interface Connectors

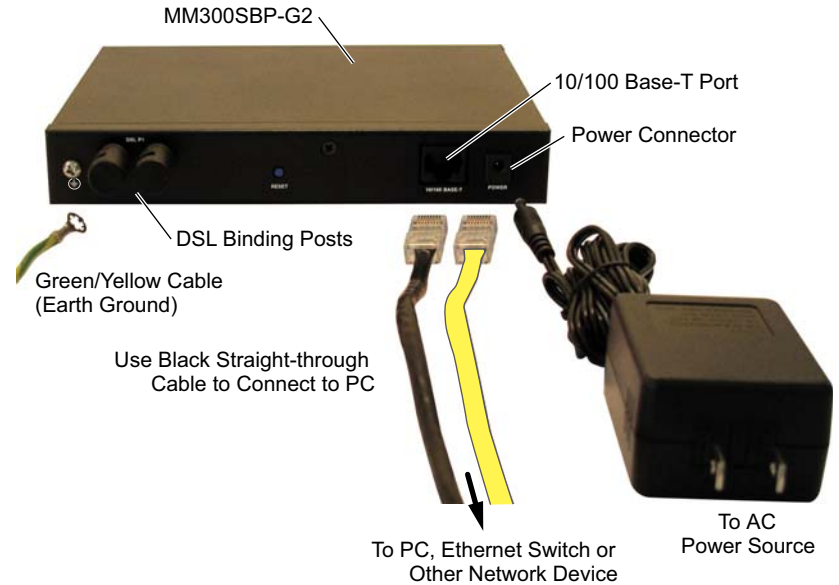

Figure 6. Cable Connections

4. Monitoring the LAN Port

Refer to **Figure 7** for monitoring the LAN Port. Also refer to **Table 1 on page 5** for the modem's normal operational LED Status.

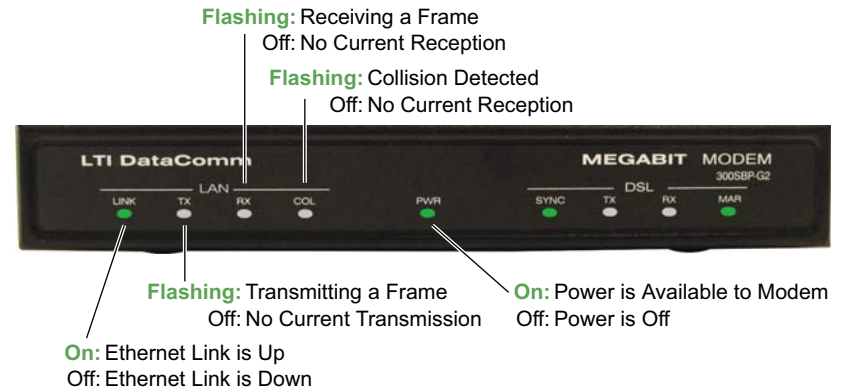

Figure 7. Monitor LAN Port

5. Monitoring the DSL Line

Refer to **Figure 8** for monitoring the DSL line. Also refer to **Table 1 on page 5** for the modem's normal operational LED Status.



- Flashing:** Establishing DSL Link
- On:** Link is Up
- Flashing:** Transmitting a Frame
- Off: No Current Transmission
- Flashing:** Receiving a Frame
- Off: No Current Reception
- On:** Margin is At or Above Margin Threshold
- Off: Margin is Below Margin Threshold

Figure 8. Monitor DSL Line

6. LED Status Indications

Table 1 summarizes the modem's normal operational status as provided by the front panel LEDs. Bold text indicates LEDs are lit (On or Flashing).

Table 1. LED Status Indicators

LED	State	Description
PWR	On green	Modem has power.
	Off	Modem does not have power.
LAN		
LINK	On green	A PC, switch or other network device is connected to the modem 10/100Base-T interface.
	Off	No device is connected to the modem 10/100Base-T interface.
TX	Flashing green	Modem is transmitting data to devices on the LAN.
	Off	Modem is not transmitting data to the LAN.
RX	Flashing green	Modem is receiving data from devices on the LAN.
	Off	Modem is not receiving data from the LAN.
COL	Flashing green	Ethernet packet collisions are occurring.
	Off	No Ethernet packet collisions are occurring.

LED	State	Description
DSL		
The service provider sets up the DSL parameters for your service. The modem must have the DSL SYNC LED lit before you can connect sessions.		
SYNC	On green	DSL transceiver is synchronized (connected) and in normal operation mode.
	Flashing green	Slow flashing green indicates that the DSL transceiver is in a start-up or handshaking sequence. Fast flashing green indicates that the DSL transceiver is in training sequence.
	Off	Power is not connected/Admin State disable
TX	Flashing green	Modem is transmitting data over the DSL connection.
	Off	Modem is not transmitting data over the DSL connection.
RX	Flashing green	Modem is receiving data over the DSL connection.
	Off	Modem is not receiving data over the DSL connection.
MAR	On green	Local SNR Margin is greater than the SNR Margin Limit.
	Off	Local SNR Margin is less than the SNR Margin Limit.

7. Troubleshooting

If the LEDs are not functioning as stated in [Table 1 on page 5](#), check the Power Supply, DSL wiring and connections and Ethernet connection. If you are still having problems, refer to [Technical Support on page 8](#).

8. Reset to Factory Defaults using the Reset Button

The reset button on the back panel of your modem is provided to reboot the modem without the need to remove power. Under normal circumstances, you will not have to use the reset button. However, on rare occasions, your modem may not respond. Then you may need to push the reset button.

Step	Action
1	Locate the Reset button on the modem's rear panel (Figure 9).
2	Use the tip of an unfolded paper clip (or similar object without a sharp tip) to gently press the Reset button (Figure 9). Hold down on the button for more than 5 seconds to restore all factory default settings. <u>IMPORTANT</u> <i>Holding down on the Reset button for LESS than 5 seconds causes the modem to reboot.</i>  <i>Holding down on the Reset button for MORE than 5 seconds causes the modem to restore all factory defaults.</i>

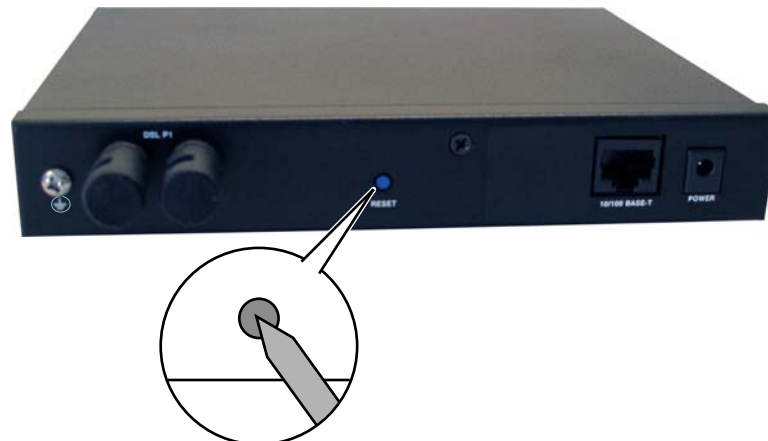

Figure 9. Restore Factory Defaults—Reset Button

DETERMINING THE DATA RATE

Figure 10 data reflects the maximum performance under no noise conditions. The actual reach depends on the condition of the line and the presence of bridge taps, splices, line noise, etc. Refer to Figure 10 for maximum data rate vs. distance and wire gauge. Noise, crosstalk and other external impairments reduce these numbers, and therefore, would fall under the plotted lines in Figure 10.

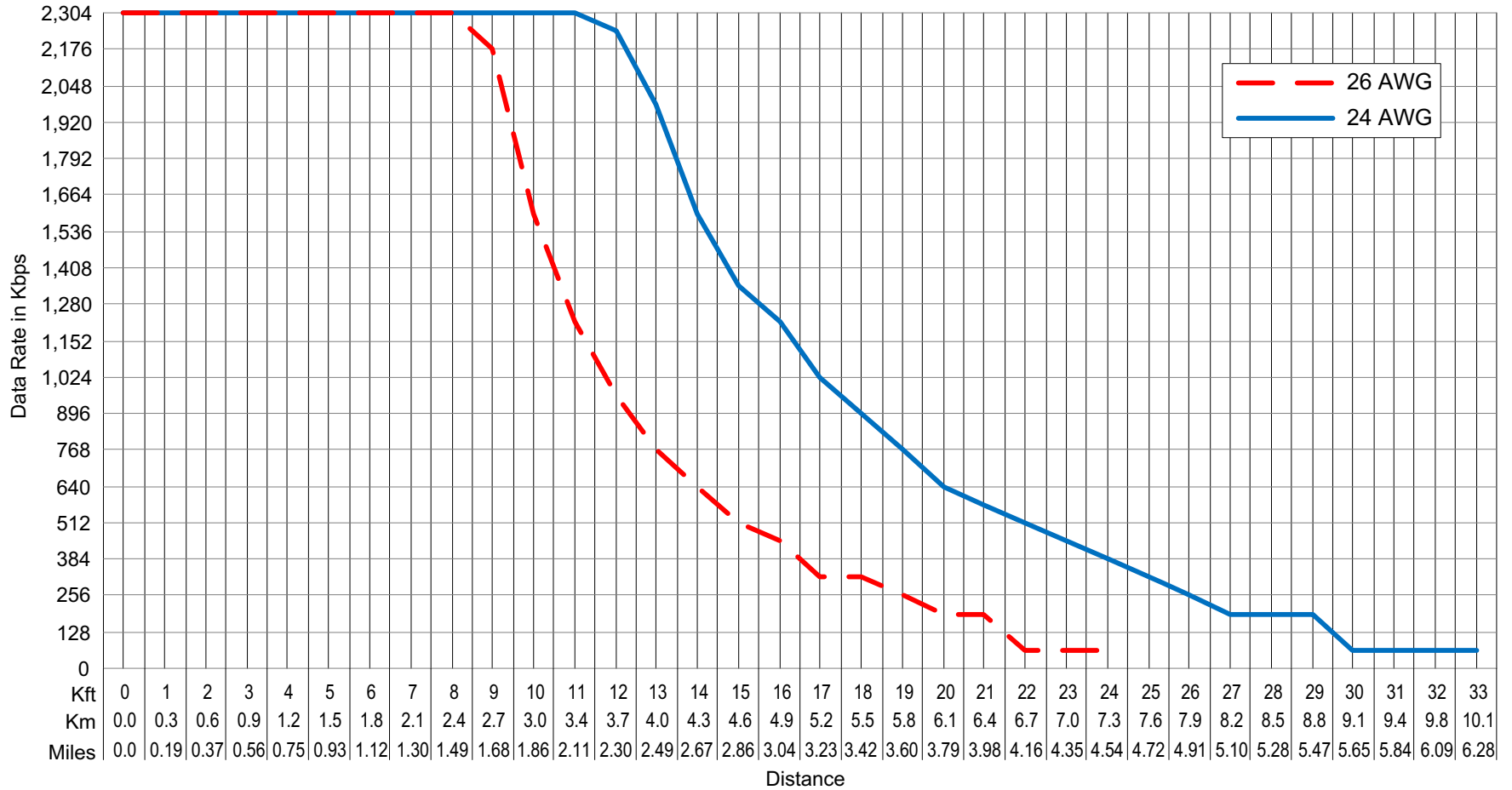

Figure 10. Maximum Data Rate Vs. Distance and Wire Gauge

HOW TO OBTAIN LTI DATAComm DOCUMENTATION

Copies of this Quick Installation Guide can be downloaded from the LTI DataComm website at <http://www.ltidata.com/customers/index.html>. To order a hard copy, please contact your sales representative.

SPECIFIC DISCLAIMER FOR HIGH-RISK ACTIVITIES

This product is not designed or intended for use in high-risk activities including, without restricting the generality of the foregoing, online control of aircraft, air traffic, aircraft navigation or aircraft communications; or in the design, construction, operation or maintenance of any nuclear facility. LTI DataComm (including its affiliates) and its suppliers specifically disclaim any express or implied warranty of fitness for such purposes or any other purposes.

FCC CLASS B COMPLIANCE

This device complies with Part 15, Class B of the FCC rules. Operation is subject to the following two conditions:

1. This device may not cause harmful interference.
2. This device must accept any interference received, including interference that may cause undesired operation.

However, there is no guarantee that interference will not occur in a particular installation. If this equipment does cause harmful interference to radio or television reception, which can be determined by turning the equipment off and on, the user is encouraged to try to correct the interference by one or more of the following measures:

- Reorient or relocate the receiving antenna.
- Increase the separation between the equipment and receiver.
- Connect the equipment into an outlet on a circuit different from that to which the receiver is connected.

Consult the dealer or an experienced radio/TV technician for help.

LIMITED WARRANTY

Product warranty is determined by your service agreement. Contact your sales representative or Customer Service for details.

MODIFICATIONS

Any changes or modifications made to this device that are not expressly approved by LTI DataComm voids the user's warranty. All wiring external to the products should follow the provisions of the current edition of the National Electrical Code.

MAILING ADDRESS

To contact LTI DataComm by mail:
LTI DataComm
23020 Eaglewood Ct - Suite 100
Sterling, VA 20166-9503

TECHNICAL SUPPORT

Technical assistance is available 24 hours a day, 7 days a week by contacting the LTI DataComm Customer Service at:

Email: info@ltidata.com

Telephone: 1.800.677.5050 (toll-free) or 1.703.581.6868

Fax: 1.703.581.6861

Web: <http://www.ltidata.com/> (click on **Contact** at the far right top of the screen)

Megabit Modem MM300SBP-G2

Quick Installation Guide

Product Catalog: MM300SBP-G2

Document: MM300SBP-G2-QI-A1

Issued September 19, 2011



300001729208

REVISION HISTORY

Rev	Date	Revisions
A1	9/19/2011	Initial Release.



© 2011 LTI DataComm. All rights Reserved.

LTI DataComm and LTI (logo) are registered trademarks of LTI DataComm. Megabit Modem is a registered trademark of ADC Telecommunications, Inc., a TE Connectivity Ltd. company. No right, license or interest to such trademarks is granted hereunder, and you agree that no such right, license or interest shall be asserted by you with respect to such trademark.

Other product names mentioned in this practice are used for identification purposes only and may be trademarks of their respective companies.

Information contained in this document is company private to LTI DataComm, and shall not be modified, used, copied, reproduced or disclosed in whole or in part without the written consent of LTI DataComm.

Contents herein are current as of the date of publication. LTI DataComm reserves the right to change the contents without prior notice. In no event shall LTI DataComm be liable for any damages resulting from loss of data, loss of use, or loss of profits, and LTI DataComm further disclaims any and all liability for indirect, incidental, special, consequential or other similar damages. This disclaimer of liability applies to all products, publications and services during and after the warranty period.